

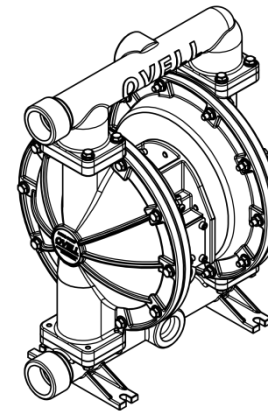

SERVICE & OPERATION MANUAL
Brief Instruction
A Series 1-1/2" Metal Pump
Aluminum / Cast Iron / Stainless Steel

Table of Contents

Performance and Material Temperature Limits2
 Designation System3
 Performance Curve4
 Dimensions5
 Principle of Pump Operation.....6
 Installation and Start-up6
 Air Supply.....6
 Air Valve Lubrication6
 Air Line Moisture6
 Air Inlet and Priming.....6
 Between Uses.....6
 Installation Guide7
 Troubleshooting8
 Warranty8
 Recycling9
 Important Safety Information9
 Exploded View10
 Parts Listing 11



A15AAXXX/A15AAXXX-L
A15AAXXX-C/A15AAXXX-C-L

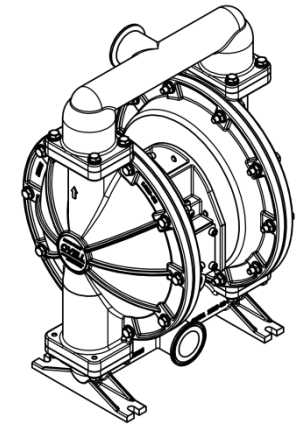

A15SAXXX-F/A15SAXXX-F-L

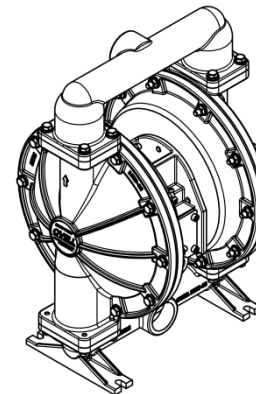

A15SAXXX/A15SAXXX-L
A15WAXXX

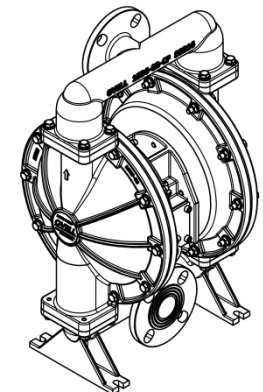

A15SAXXX-CF/A15SAXXX-CF-L

****Note: Not ATEX Compliant**

Performance and Material Temperature Limits

Performance

| | | | |
|------------------|-----------------------|-----------------------------------|---------|
| Air Inlet | Refer to "Dimensions" | Maximum Working Pressure | 8.3 bar |
| Inlet | Refer to "Dimensions" | Maximum Flow Rate (flooded inlet) | 380 lpm |
| Outlet | Refer to "Dimensions" | Maximum Particle Size | 6.5mm |
| Suction Lift Dry | 5.2m | | |

Temperature Limits

| Material profile: Caution! Operating temperature limitations are as follows: | Operation temperature | |
|--|-----------------------|------------------|
| | Max. | Min. |
| Santoprene®: Injection molded thermoplastic elastomer with no fabric layer. Long mechanical flex life. Excellent abrasion resistance. | 275 °F 135 °C | -40 °F -40 °C |
| Virgin PTFE: (PFA/TFE) Chemically inert, virtually impervious. Very few chemicals are known to chemically react with PTFE. molten alkali metals, turbulent liquid or gaseous fluorine and a few fluoro-chemicals such as chlorine trifluoride or oxygen difluoride which readily liberate free fluorine at elevated temperature. | 220 °F 104 °C | -35 °F -37 °C |
| PVDF: (Polyvinylidene Fluoride) A durable fluoroplastic with excellent chemical resistance. Excellent for UV applications. High tensile strength and impact resistance. | 250 °F 121 °C | 0 °F -18 °C |
| Polypropylene: A thermoplastic polymer, moderate tensile and flex strength. Resists strong acids and alkali. Attacked by chlorine, fuming nitric acid and other strong oxidizing agents. | 175 °F 79 °C | 32 °F 0 °C |
| EPDM: Shows very good water and chemical resistance, Has poor resistance to oils and solvents, but is fair in ketones and alcohols. | 280 °F 138 °C | -40 °F -40 °C |
| Hytrel®: Good on acids, bases, amines and glycols at room temperature only. | 220 °F 140 °C | -20 °F -29 °C |
| Neoprene: All purpose. resistance to vegetable oils, Generally not affected by moderate chemicals, fats, greases and many oils and solvents. Generally attacked by strong oxidizing acids, ketones, esters and nitro hydrocarbons and chlorinated aromatic hydrocarbons. | 200 °F 93 °C | -10 °F -23 °C |
| Nitrile: General purpose, oil-resistant. Shows good solvent, oil, water and hydraulic fluid resistance. Should not be used with highly polar solvents like acetone and MEK, ozone, chlorinated hydrocarbons and nitro hydrocarbons. | 190 °F 88 °C | -10 °F -23 °C |
| Viton FKM(fluorocarbon): Shows good resistance to a wide range of oils and solvents; especially all aliphatic and halogenated hydrocarbons, acids, animal and vegetable oils. Hot water or hot aqueous solutions (over 70 °F) will attack KFM. | 350 °F 177 °C | -40 °F -40 °C |

Designation System

| | | | | | | | | | | | | | | | |
|-------------------|--------------------------------|---------------|--|-----------|----------------------------|----------|---------------------------|---------------------|----------------------------|------------|----------------------------|---------------|---------------------------|-----------------|------------|
| A | 15 | X | X | X | X | X | X | X | X | X | X | X | X | X | - X |
| Series No. | Size of Inlet or Outlet | | Material of Manifolds or Fluid Caps | | Motor Body Material | | Diaphragm Material | | Valve Ball Material | | Valve Seat Material | | Application Fields | | |
| A | 15 | 1-1/2" | A | Aluminum | A | Aluminum | T | Teflon & Santoprene | T | Teflon | A | Aluminum | F | Food Processing | |
| | | | S | SS316 | | | G | Santoprene | G | Santoprene | S | SS316 | C | Center Port | |
| | | | W | Cast Iron | | | B | Buna-n | B | Buna-n | G | Santoprene | CF | Center Flange | |
| | | | | | | | V | Viton | V | Viton | P | Polypropylene | L | Li-ion | |
| | | | | | | | N | Neoprene | N | Neoprene | | | | | |
| | | | | | | | E | EPDM | E | EPDM | | | | | |

Performance Curve

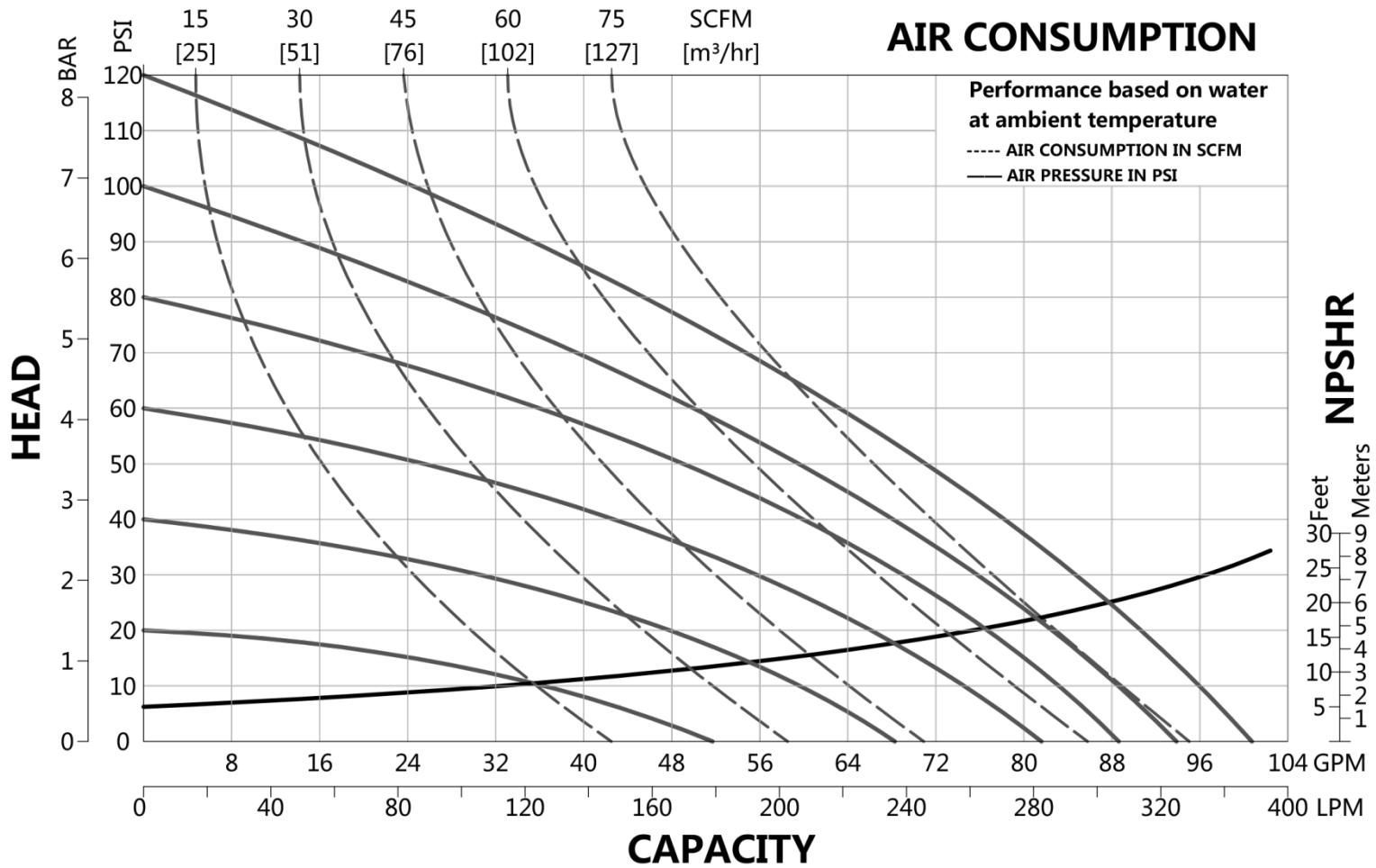

Dimensions

Dimensions in millimeters

Dimensional tolerance: ± 3 mm

A15SAXXX / A15WAXXX / A15SAXXX-L

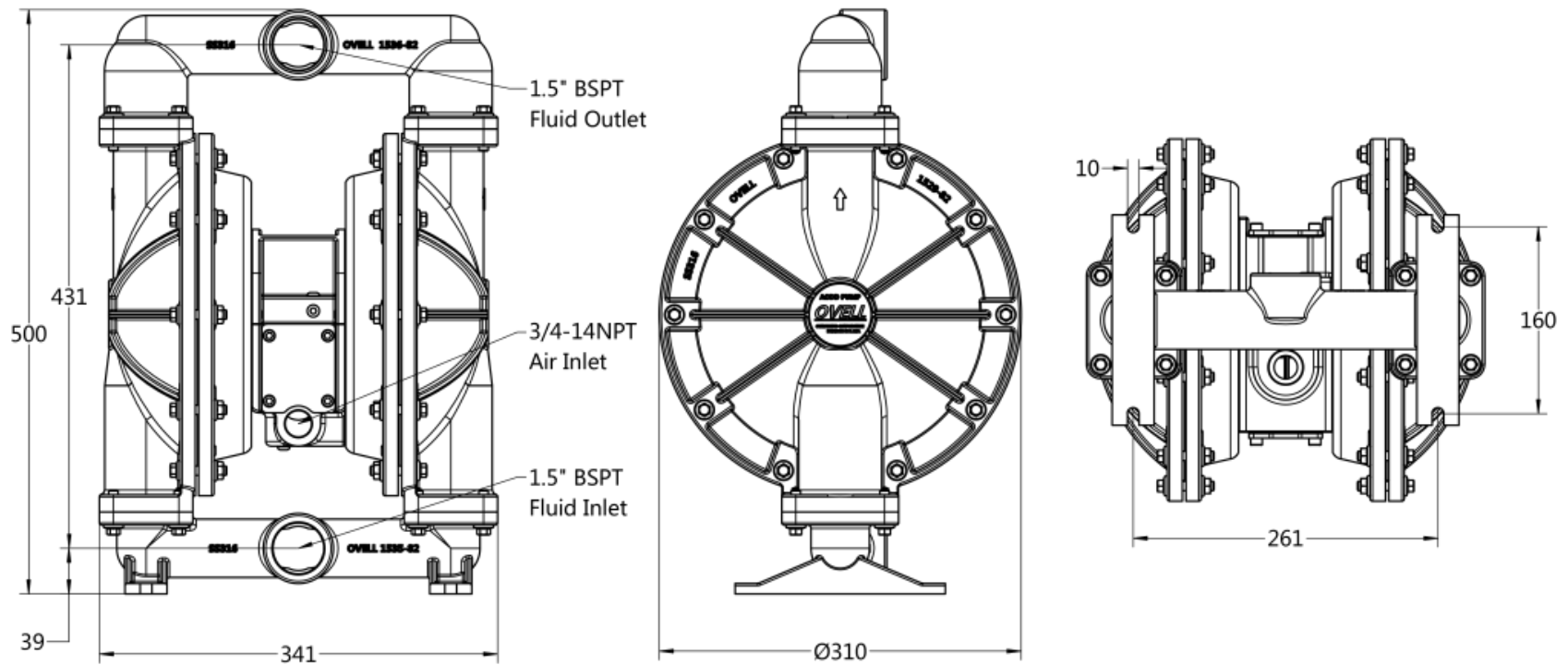

A15AAXX / A15AAXX-C / A15AAXX-L

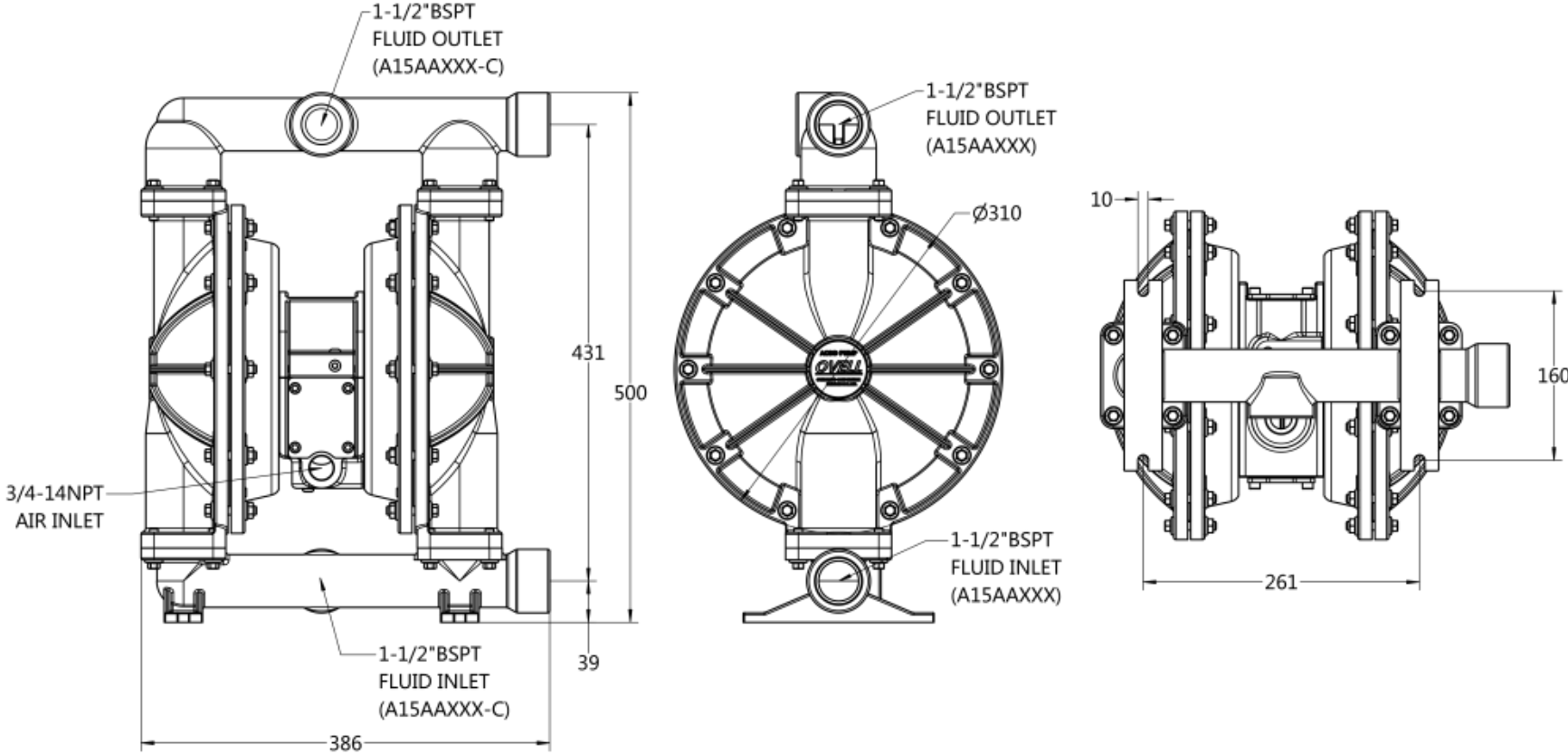

A15SAXXX-CF / A15SAXXX-CF-L

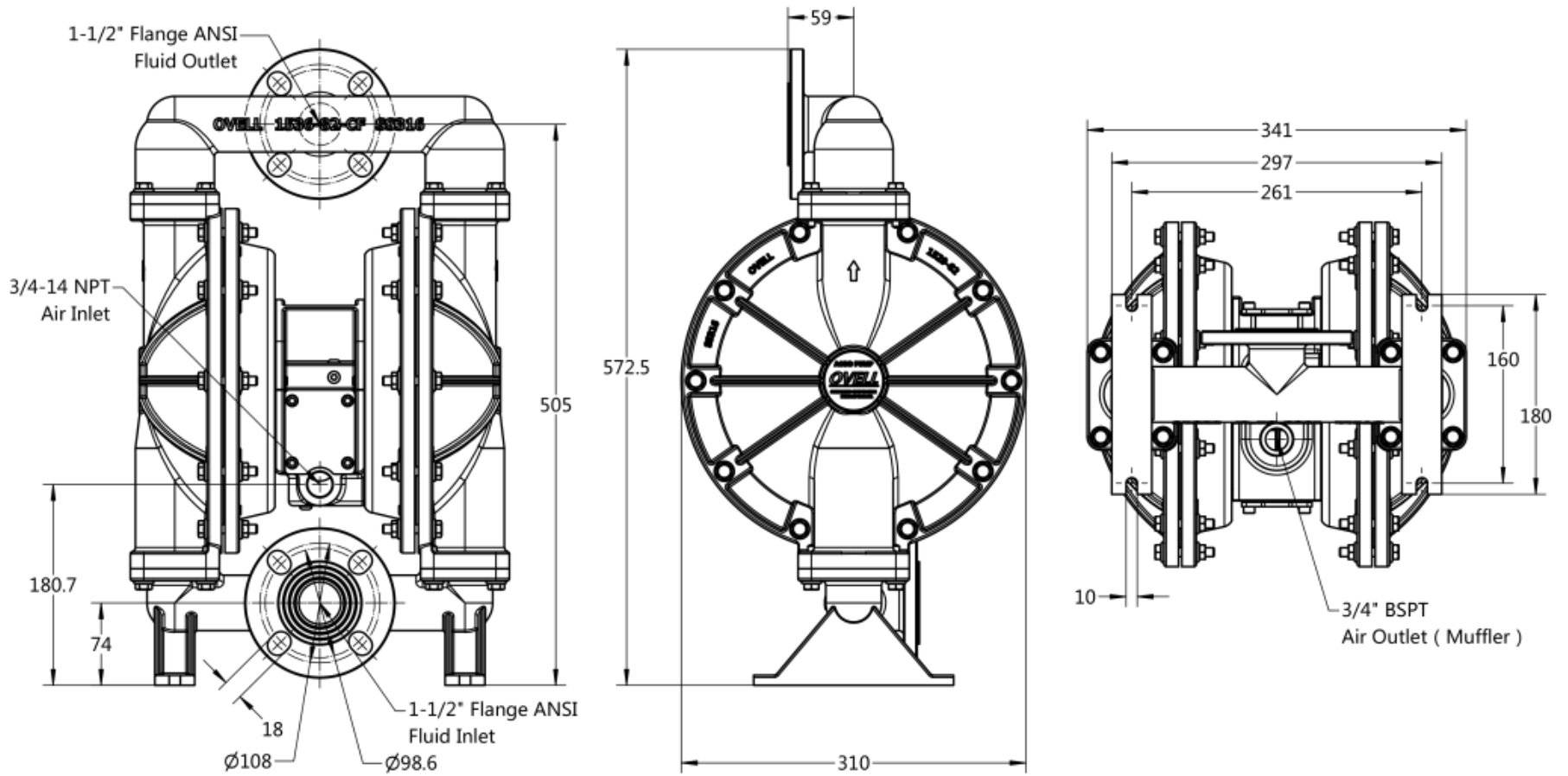

A15SAXXX-F / A15SAXXX-F-L

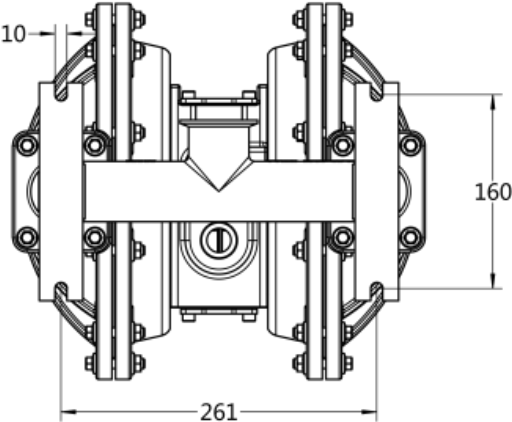
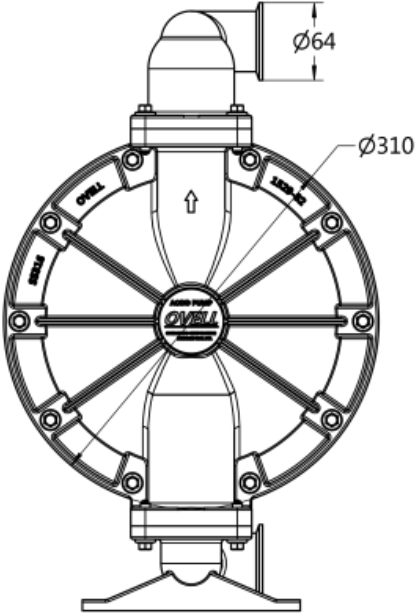
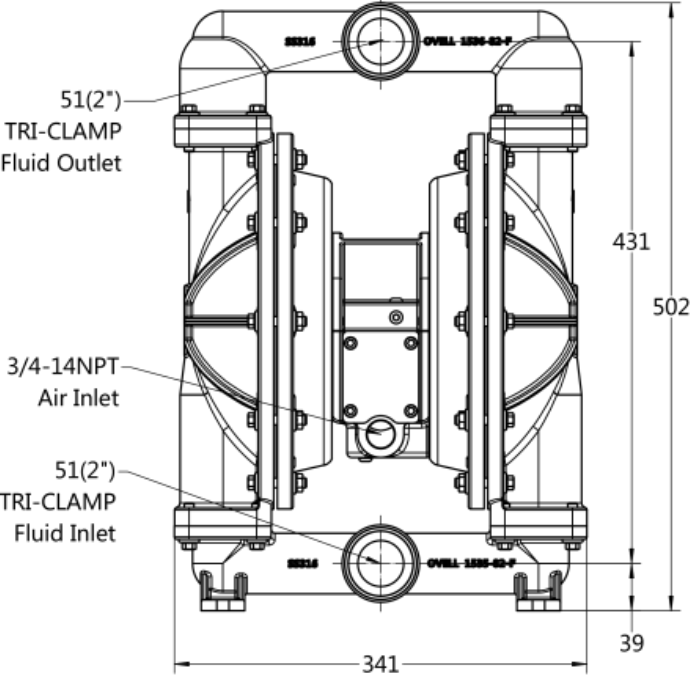

PRINCIPLE OF PUMP OPERATION

This ball type check valve pump is powered by compressed air and is a 1:1 ratio design. The inner side of one diaphragm chamber is alternately pressurized while simultaneously exhausting the other inner chamber. This causes the diaphragms, which are connected by a common rod secured by plates to the centers of the diaphragms, to move in a reciprocating action. (As one diaphragm performs the discharge stroke the other diaphragm is pulled to perform the suction stroke in the opposite chamber.) Air pressure is applied over the entire inner surface of the diaphragm while liquid is discharged from the opposite side of the diaphragm. The diaphragm operates in a balanced condition during the discharge stroke which allows the pump to be operated at discharge heads over 200 feet (61 meters) of water.

For maximum diaphragm life, keep the pump as close to the liquid being pumped as possible. Positive suction head in excess of 10 feet of liquid (3.048 meters) may require a back pressure regulating device to maximize diaphragm life.

Alternate pressurizing and exhausting of the diaphragm chamber is performed by an externally mounted, pilot operated, four way spool type air distribution valve. When the spool shifts to one end of the valve body, inlet pressure is applied to one diaphragm chamber and the other diaphragm chamber exhausts. When the spool

shifts to the opposite end of the valve body, the pressure to the chambers is reversed. The air distribution valve spool is moved by an internal pilot valve which alternately pressurizes one end of the air distribution valve spool while exhausting the other end. The pilot valve is shifted at each end of the diaphragm stroke when an actuator plunger is contacted by the diaphragm plate. This actuator plunger then pushes the end of the pilot valve spool into position to activate the air distribution valve.

The chambers are connected with manifolds with a suction and discharge check valve for each chamber, maintaining flow in one direction through the pump.

INSTALLATION AND START-UP

Locate the pump as close to the product being pumped as possible. Keep the suction line length and number of fittings to a minimum. Do not reduce the suction line diameter.

For installations of rigid piping, short sections of flexible hose should be installed between the pump and the piping. The flexible hose reduces vibration and strain to the pumping system. To reduce the pulsation in flow a suggestion to install a surge suppressor in discharge pipe line.

AIR SUPPLY

Air supply pressure cannot exceed 125 psi (8.6 bar). Connect the pump air inlet to an air supply of sufficient capacity and pressure required for desired performance. When the air

supply line is solid piping, use a short length of flexible hose not less than ½" (13mm) in diameter between the pump and the piping to reduce strain to the piping. The weight of the air supply line, regulators and filters must be supported by some means other than the air inlet cap. Failure to provide support for the piping may result in damage to the pump. A pressure regulating valve should be installed to insure air supply pressure does not exceed recommended limits.

AIR VALVE LUBRICATION

The air distribution system adopts a lubrication-free design, which is the standard operating mode. If the user's actual air source quality is not good or there are special circumstances, consider lubricating the air circuit. But please try to consult the agent or manufacturer in advance.

AIR LINE MOISTURE

Water in the compressed air supply can create problems such as icing or freezing of the exhaust air, causing the pump to cycle erratically or stop operating. Water in the air supply can be reduced by using a point-of-use air dryer

to supplement the user's air drying equipment. This device removes water from the compressed air supply and alleviates the icing or freezing problems.

AIR INLET AND PRIMING

To start the pump, open the air valve approximately ½ to ¾ turn. After the pump primes, the air valve can be opened to increase air flow as desired. If opening the valve increases cycling rate, but does not increase the rate of flow, cavitation has occurred. The valve should be closed slightly to obtain the most efficient air flow to pump flow ratio.

BETWEEN USES

When the pump is used for materials that tend to settle out or solidify when not in motion, the pump should be flushed after each use to prevent damage. (Product remaining in the pump between uses could dry out or settle out. This could cause problems with the diaphragms and check valves at restart.) In freezing temperatures the pump must be completely drained between uses in all cases.

TYPICAL INSTALLATION GUIDE

Available From Overalllead Inc.

| | |
|--|--|
| | <p>CAUTION The air exhaust should be piped to an area for safe disposition of the product being pumped, in the event of a diaphragm failure.</p> |
|--|--|

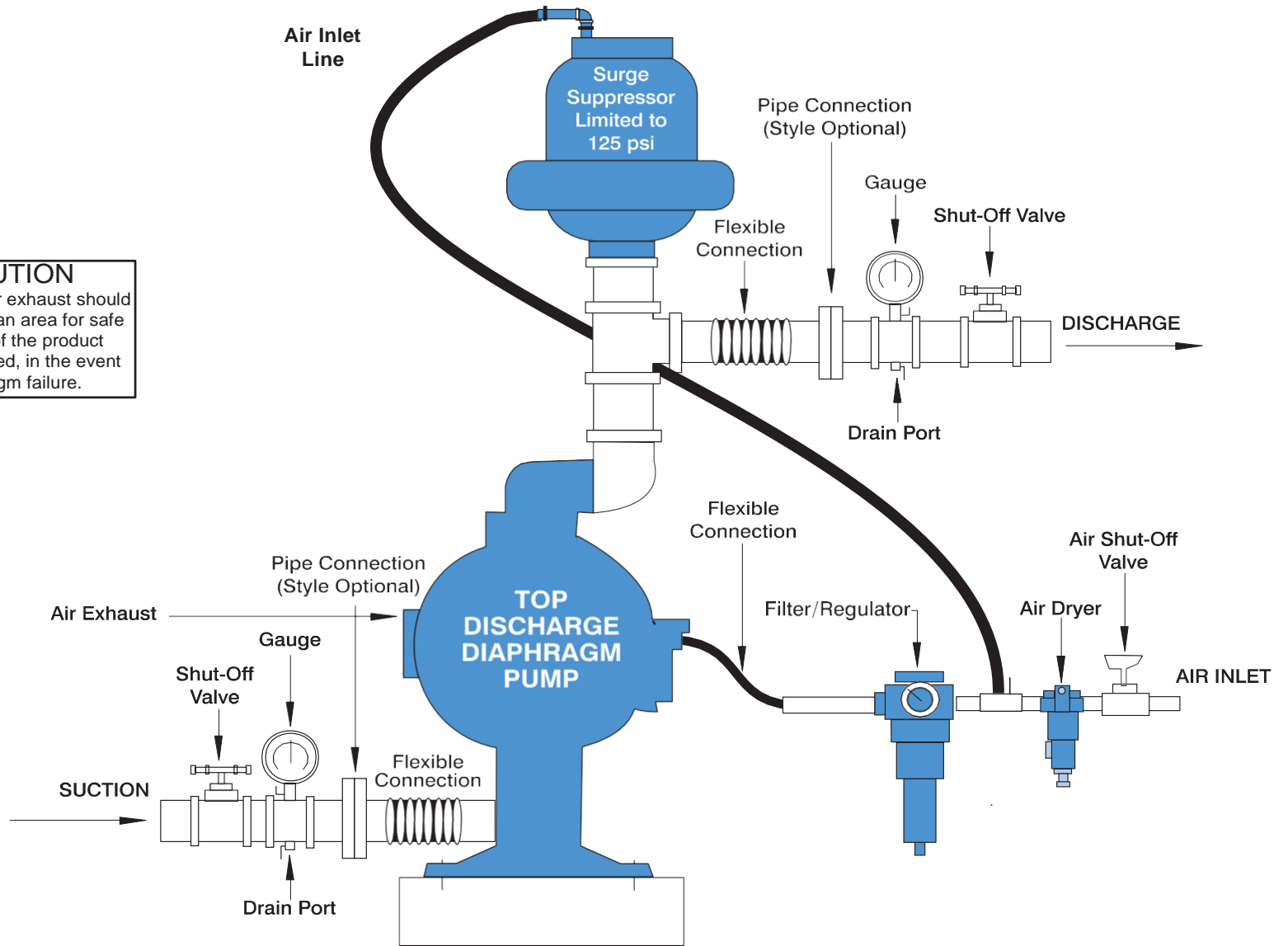

TROUBLESHOOTING

Possible Symptoms:

- Pump will not cycle.
- Pump cycles, but produces no flow.
- Pump cycles, but flow rate is unsatisfactory.
- Pump cycle seems unbalanced.
- Pump cycle seems to produce excessive vibration.

What to Check: Excessive suction lift in system.

Corrective Action: For lifts exceeding 20 feet (6 meters), filling the pumping chambers with liquid will prime the pump in most cases.

What to Check: Excessive flooded suction in system.

Corrective Action: For flooded conditions exceeding 10 feet (3 meters) of liquid, install a back pressure device.

What to Check: System head exceeds air supply pressure.

Corrective Action: Increase the inlet air pressure to the pump. Most diaphragm pumps are designed for 1:1 pressure ratio at zero flow.

What to Check: Air supply pressure or volume exceeds system head.

Corrective Action: Decrease inlet air pressure and volume to the pump as calculated on the published PERFORMANCE CURVE. Pump is cavitating the fluid by fast cycling.

What to Check: Undersized suction line.

Corrective Action: Meet or exceed pump connection recommendations shown on the DIMENSIONAL DRAWING.

What to Check: Restricted or undersized air line.

Corrective Action: Install a larger air line and connection. Refer to air inlet recommendations shown in your pump's SERVICE MANUAL.

What to Check: Check ESADS, the Externally Serviceable Air Distribution System of the pump.

Corrective Action: Disassemble and inspect the main air distribution valve, pilot valve and pilot valve actuators. Refer to the parts drawing and air valve section of the SERVICE MANUAL. Check for clogged discharge or closed valve before reassembly.

What to Check: Rigid pipe connections to pump.

Corrective Action: Install flexible connectors and a surge suppressor.

What to Check: Blocked air exhaust muffler.

Corrective Action: Remove muffler screen, clean or de-ice and reinstall. Refer to the Air Exhaust section of your pump SERVICE MANUAL.

What to Check: Pumped fluid in air exhaust muffler.

Corrective Action: Disassemble pump chambers. Inspect for diaphragm rupture or loose diaphragm plate assembly. Refer to the Diaphragm Replacement section of your pump SERVICE MANUAL.

What to Check: Suction side air leakage or air inproduct.

Corrective Action: Visually inspect all suction side gaskets and pipe connections.

What to Check: Obstructed check valve.

Corrective Action: Disassemble the wet end of the pump and manually dislodge obstruction in the check valve pocket. Refer to the Check Valve section of the pump SERVICE MANUAL for disassembly instructions.

What to Check: Worn or misaligned check valve or check valve seat.

Corrective Action: Inspect check valves and seats for wear and proper seating. Replace if necessary. Refer to Check Valve section of the pump SERVICE MANUAL for disassembly instructions.

What to Check: Blocked suction line.

Corrective Action: Remove or flush obstruction. Check and clear all suction screens and strainers.

What to Check: Blocked discharge line.

Corrective Action: Check for obstruction or closed discharge line valves.

What to Check: Blocked pumping chamber.

Corrective Action: Disassemble and inspect the wetted chambers of the pump. Remove or flush any obstructions. Refer to the pump SERVICE MANUAL for disassembly instructions.

What to Check: Entrained air or vapor lock in one or both pumping chambers.

Corrective Action: Purge chambers through tapped chamber vent plugs. PURGING THE CHAMBERS OF AIR CAN BE DANGEROUS! Contact the Overallled Technical Services Group before performing this procedure. Any model with top-ported discharge will reduce or eliminate problems with entrained air.

If your pump continues to perform below your expectations, contact your local Overallled Distributor or factory Technical Services Group for a service evaluation.

RECYCLING

Many components of OVELL AODD pumps are made of recyclable materials. We encourage pump users to recycle worn out parts and pumps whenever possible, after any hazardous pumped fluids are thoroughly flushed.

IMPORTANT SAFETY INFORMATION



IMPORTANT

Read these safety warnings and instructions in this manual completely, before installation and start-up of the pump. It is the responsibility of the purchaser to retain this manual for reference. Failure to comply with the recommendations stated in this manual will damage the pump, and void factory warranty.



CAUTION

Before pump operation, inspect all gasketed fasteners for looseness caused by gasket creep. Re-torque loose fasteners to prevent leakage. Follow recommended torques stated in this manual.



WARNING

Before maintenance or repair, shut off the compressed air line, bleed the pressure, and disconnect the air line from the pump. The discharge line may be pressurized and must be bled of its pressure.



WARNING

In the event of diaphragm rupture, pumped material may enter the air end of the pump, and be discharged into the atmosphere. If pumping a product which is hazardous or toxic, the air exhaust must be piped to an appropriate area for safe disposition.



WARNING

Take action to prevent static sparking. Fire or explosion can result, especially when handling flammable liquids. The pump, piping, valves, containers or other miscellaneous equipment must be grounded. (See Page 8)



WARNING

This pump is pressurized internally with air pressure during operation. Always make certain that all bolting is in good condition and that all of the correct bolting is reinstalled during assembly.



WARNING

When used for toxic or aggressive fluids, the pump should always be flushed clean prior to disassembly.



WARNING

Before doing any maintenance on the pump, be certain all pressure is completely vented from the pump, suction, discharge, piping, and all other openings and connections. Be certain the air supply is locked out or made non-operational, so that it cannot be started while work is being done on the pump. Be certain that approved eye protection and protective clothing are worn all times in the vicinity of the pump. Failure to follow these recommendations may result in serious injury or death.



WARNING

Airborne particles and loud noise hazards. Wear ear and eye protection.

Exploded View

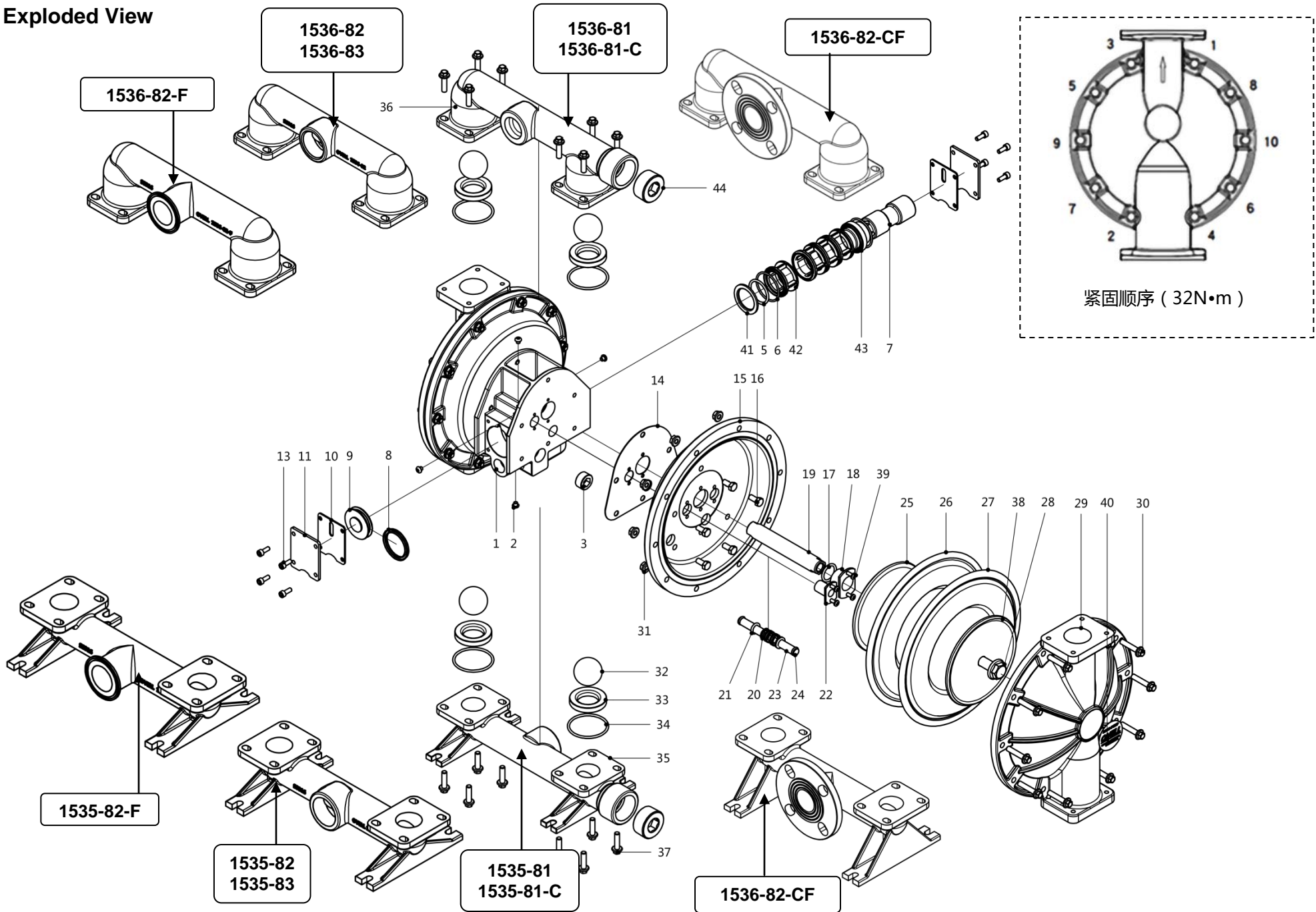

Parts Listing

| Item | Description | Part NO. | QTY |
|------|-------------------|-----------|-----|
| 1 | Motor Body | 2001-81 | 1 |
| 2 | Button Head Screw | 1002-82 | 4 |
| 3 | Pipe Plug | 2003-83 | 1 |
| △5 | O Ring | 2005-87 | 5 |
| △6 | O Ring | 2006-87 | 6 |
| 7 | Spool | 2007-81 | 1 |
| △8 | U Cup | 2008-87 | 1 |
| 9 | Piston | 2009-84 | 1 |
| △10 | Gasket | 2010-87 | 2 |
| 11 | Plate | 2011-82 | 2 |
| 13 | Bolt | 2013-82 | 8 |
| △14 | Washer | 2014-87 | 2 |
| 15 | Air Cap | 1515-81 | 2 |
| 16 | Bolt | 2016-83 | 12 |
| △▲17 | O Ring | 2017-87 | 2 |
| 18 | Sleeve Bushing | 2018-81 | 2 |
| | | 2018-84 | |
| 19 | Shaft | 1519-83 | 1 |
| △20 | Spacer | 1017-81 | 3 |
| | | 1017-81-L | |
| △21 | O Ring | 1016-90 | 4 |
| 22 | Sleeve Bushing | 2022-81 | 2 |
| | | 2022-84 | |
| 23 | Pilot Rod | 2023-83 | 1 |
| △24 | O Ring | 1022-85 | 2 |
| 25 | Plate | 1525-83 | 2 |
| | | 1525-82 | |
| ▲26 | Diaphragm | 1526-85 | 2 |
| | | 1526-87 | |
| | | 1526-88 | |
| | | 1526-89 | |
| | | 1526-92 | |
| | | 1586-92 | |
| ▲27 | Diaphragm | 1527-86 | 2 |
| | | 1587-86 | |
| 28 | Bolt | 1528-82 | 2 |
| 29 | Fluid Cap | 1529-81 | 2 |
| | | 1529-81-L | |
| | | 1529-82 | |
| | | 1529-83 | |

| Item | Description | Part NO. | QTY |
|---------|-----------------|------------|-----|
| 30 | Bolt | 1530-83 | 20 |
| | | 1530-82 | |
| 31 | Nut | 1531-83 | 20 |
| | | 1531-82 | |
| ▲32 | Valve Ball | 1532-86 | 4 |
| | | 1532-85 | |
| | | 1532-88 | |
| | | 1532-92 | |
| | | 1532-87 | |
| | | 1532-89 | |
| 33 | Valve Seat | 1533-81 | 4 |
| | | 1533-82 | |
| | | 1533-84 | |
| | | ▲1533-85 | |
| ▲34 | O Ring | 1534-86 | 4 |
| | | 1534-89 | |
| 35 | Inlet Manifold | 1535-81 | 1 |
| | | 1535-81-C | |
| | | 1535-81-L | |
| | | 1535-82 | |
| | | 1535-82-F | |
| | | 1535-82-CF | |
| | | 1535-83 | |
| 36 | Outlet Manifold | 1536-81 | 1 |
| | | 1536-81-C | |
| | | 1536-81-L | |
| | | 1536-82 | |
| | | 1536-82-CF | |
| | | 1536-82-F | |
| 1536-83 | | | |
| 37 | Bolt | 1537-83 | 16 |
| | | 1537-82 | |
| 38 | Plate | 1525-83 | 2 |
| 39 | Bolt | 1525-82 | 2 |
| | | 2039-82 | |
| 41 | Washer | 2041-81 | 1 |
| | | 2041-81-L | |
| 42 | Spacer | 2042-81 | 4 |
| | | 2042-81-L | |
| 43 | Washer | 2043-81 | 1 |
| | | 2043-81-L | |
| 44 | Screw | 1589-83 | 2 |
| | | 1589-82 | |

| Material No. | Material |
|--------------|------------------------|
| 81 | Alumimum Alloy |
| 82 | Stainless Steel |
| 83 | Carbon Steel |
| 84 | Plastic |
| 85 | Santoprene |
| 86 | PTFE,Teflon |
| 87 | Buna N, Nitril |
| 88 | Fluororubber,Viton |
| 89 | EPDM |
| 90 | PU(Polyurethane) |
| 91 | Hytrel |
| 92 | Neoprene |
| 93 | Assembly, Sub-assembly |
| 94 | Paper |
| 95 | Cuprum |
| 96 | PTFE & Fluororubber |
| 97 | FFKM |
| 99 | PVDF (Kynar) |
| 00 | Lubricant |

| ENCLOSURE | | |
|-------------|----------|-----|
| Description | Part No. | QTY |
| Muffler | 1556-93 | 1 |
| | 1556-82 | |
| Elbow | 1588-82 | 1 |

“△”: Air Valve Service Kit 7020 (Including Lubricant 1000-00)

“▲”: Fluid Section Service Kit 8015 (Including Lubricant 1000-00)

Notice : Item 27 only use for A15XXTXX

Notice : Item 27 must be used together with item 26

Notice : " 1586-92" must be used together with "1587-86"

Notice : Item 44 only use for A15AAXXX-C

Notice : Item 33 If "1533-85" is selected, Item 34 is required

Notice : Item 33 "1533-85" Into the fluid Section Service Kit

Notice : The lithium industry pump type is recommended to be suffixed with "-L" parts.



Declaration of Conformity

Manufacturer:

**Overallead Corporation, Room 902, No.2 Building, No. 3, Chanxing 1st Road,
Xianchong Village, Chencun Town, Shunde District, Foshan City, Guangdong Province,
China**

Certifies that Air-Operated Double Diaphragm Pumps Series:

A Non-Metallic, A Metallic comply with the European Machinery Directive 2006/42/EC. This product has used EN ISO12100:2010, EN809:1998+A1:2009, EN ISO4414:2010 Pumps and Pump Units for Liquids - Common Safety Requirements harmonized standard to verify conformance.

Pump Models:

A05APabc, A10AAabc, A15AAabc, A20AAabc, A30AAabc, A05APabc-L, A10AAabc-L, A15AAabc-L,
A20AAabc-L, A30AAabc-L, A05SPabc, A10SAabc, A15SAabc, A20SAabc, A30SAabc, A02P(K)Pabc,
A05P(K)Pabc, A10P(K)Pabc, A15P(K)Pabc, A20P(K)Pabc, A30P(K)Pabc
(a=T, G, B, H, V, N, E indicate different Diaphragm Material;
b=T, G, B, S, V, N, E indicate different Ball Material;
c=A, S, P, C, G, K, T indicate different Ball Seat Material)



A handwritten signature in black ink, appearing to read "Peter Lee".

Peter Lee
Quality Representative

August 1, 2022