

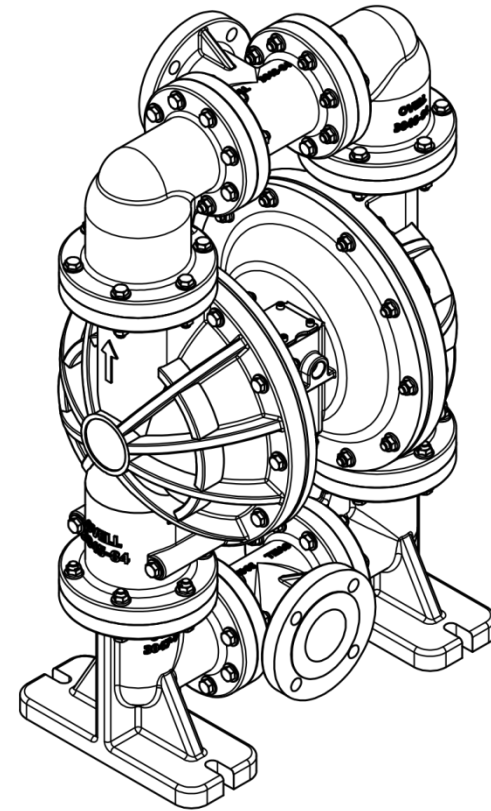

SERVICE & OPERATION MANUAL
Brief Instruction
A Series 3" Plastic Pump
Polypropylene(PP) / Polyvinylidene Fluoride(PVDF)

Table of Contents

Engineering Data and Temperature Limitations.....1
Performance and Material Temperature Limits2
Designation System3
Performance Curve4
Dimensions5
Principle of Pump Operation.....6
Installation and Start-up6
Air Supply.....6
Air Valve Lubrication6
Air Line Moisture6
Air Inlet and Priming.....6
Between Uses6
Installation Guide7
Troubleshooting8
Warranty8
Recycling9
Important Safety Information9
Exploded View..10
Parts Listing.....11



A30PAXXX / A30KAXXX
A30PAXXX-L / A30KAXXX-L

****Note: Not ATEX Compliant**

Performance and Material Temperature Limits

Performance

Air Inlet	Refer to "Dimensions"	Maximum Working Pressure	8.3 bar
Inlet	Refer to "Dimensions"	Maximum Flow Rate (flooded inlet)	902 lpm
Outlet	Refer to "Dimensions"	Maximum Particle Size	10mm
Suction Lift Dry	4.8m		

Temperature Limits

Material profile: Caution! Operating temperature limitations are as follows:	Operation temperature	
	Max.	Min.
Santoprene®: Injection molded thermoplastic elastomer with no fabric layer. Long mechanical flex life. Excellent abrasion resistance.	275 °F 135 °C	-40 °F -40 °C
Virgin PTFE: (PFA/TFE) Chemically inert, virtually impervious. Very few chemicals are known to chemically react with PTFE. molten alkali metals, turbulent liquid or gaseous fluorine and a few fluoro-chemicals such as chlorine trifluoride or oxygen difluoride which readily liberate free fluorine at elevated temperature.	220 °F 104 °C	-35 °F -37 °C
PVDF: (Polyvinylidene Fluoride) A durable fluoroplastic with excellent chemical resistance. Excellent for UV applications. High tensile strength and impact resistance.	250 °F 121 °C	0 °F -18 °C
Polypropylene: A thermoplastic polymer, moderate tensile and flex strength. Resists strong acids and alkali. Attacked by chlorine, fuming nitric acid and other strong oxidizing agents.	175 °F 79 °C	32 °F 0 °C
EPDM: Shows very good water and chemical resistance, Has poor resistance to oils and solvents, but is fair in ketones and alcohols.	280 °F 138 °C	-40 °F -40 °C
Hytrel®: Good on acids, bases, amines and glycols at room temperature only.	220 °F 140 °C	-20 °F -29 °C
Neoprene: All purpose. resistance to vegetable oils, Generally not affected by moderate chemicals, fats, greases and many oils and solvents. Generally attacked by strong oxidizing acids, ketones, esters and nitro hydrocarbons and chlorinated aromatic hydrocarbons.	200 °F 93 °C	-10 °F -23 °C
Nitrile: General purpose, oil-resistant. Shows good solvent, oil, water and hydraulic fluid resistance. Should not be used with highly polar solvents like acetone and MEK, ozone, chlorinated hydrocarbons and nitro hydrocarbons.	190 °F 88 °C	-10 °F -23 °C
Viton FKM(fluorocarbon): Shows good resistance to a wide range of oils and solvents; especially all aliphatic and halogenated hydrocarbons, acids, animal and vegetable oils. Hot water or hot aqueous solutions (over 70 °F) will attack KFM.	350 °F 177 °C	-40 °F -40 °C

Designation System

A	30	X	X	X	X	X	-X
----------	-----------	----------	----------	----------	----------	----------	-----------

Series No	Size of Inlet or Outlet		Material of Manifolds or Fluid Caps		Motor Body Material		Diaphragm Material		Valve Ball Material		Valve Seat Material		Special Requirements	
			P		A		T		T		P		L	
A	30	3"	P	Polypropylene	A	Aluminum	T	Teflon & Santoprene	T	Teflon	P	Plastic	L	Lion
			K	PVDF			G	Santoprene	G	Santoprene	K	PVDF		
											G	Santoprene		
											S	Stainless Steel		

Performance Curve

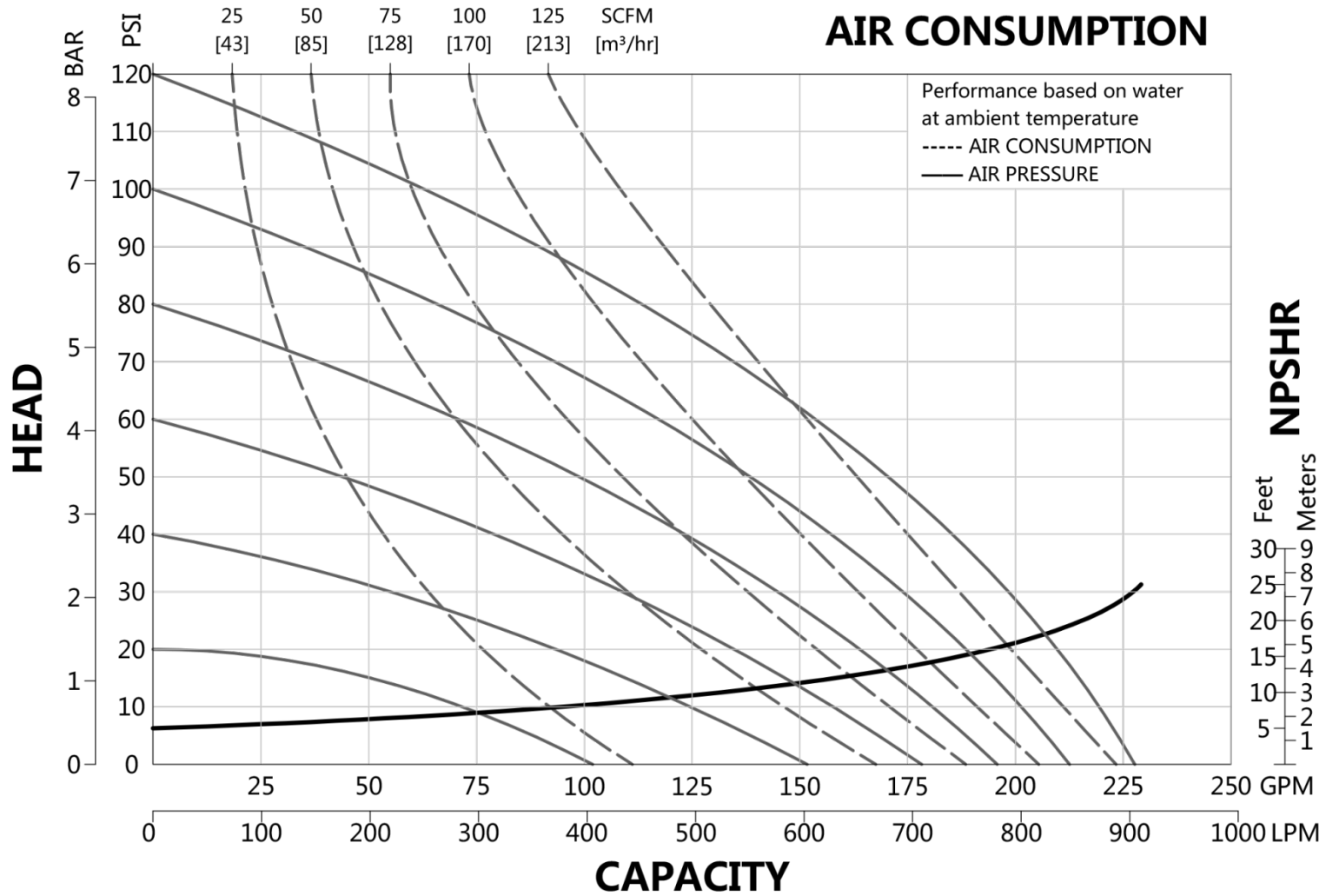

Dimensions:

Dimensions in millimeters

Dimensional tolerance: $\pm 3\text{mm}$

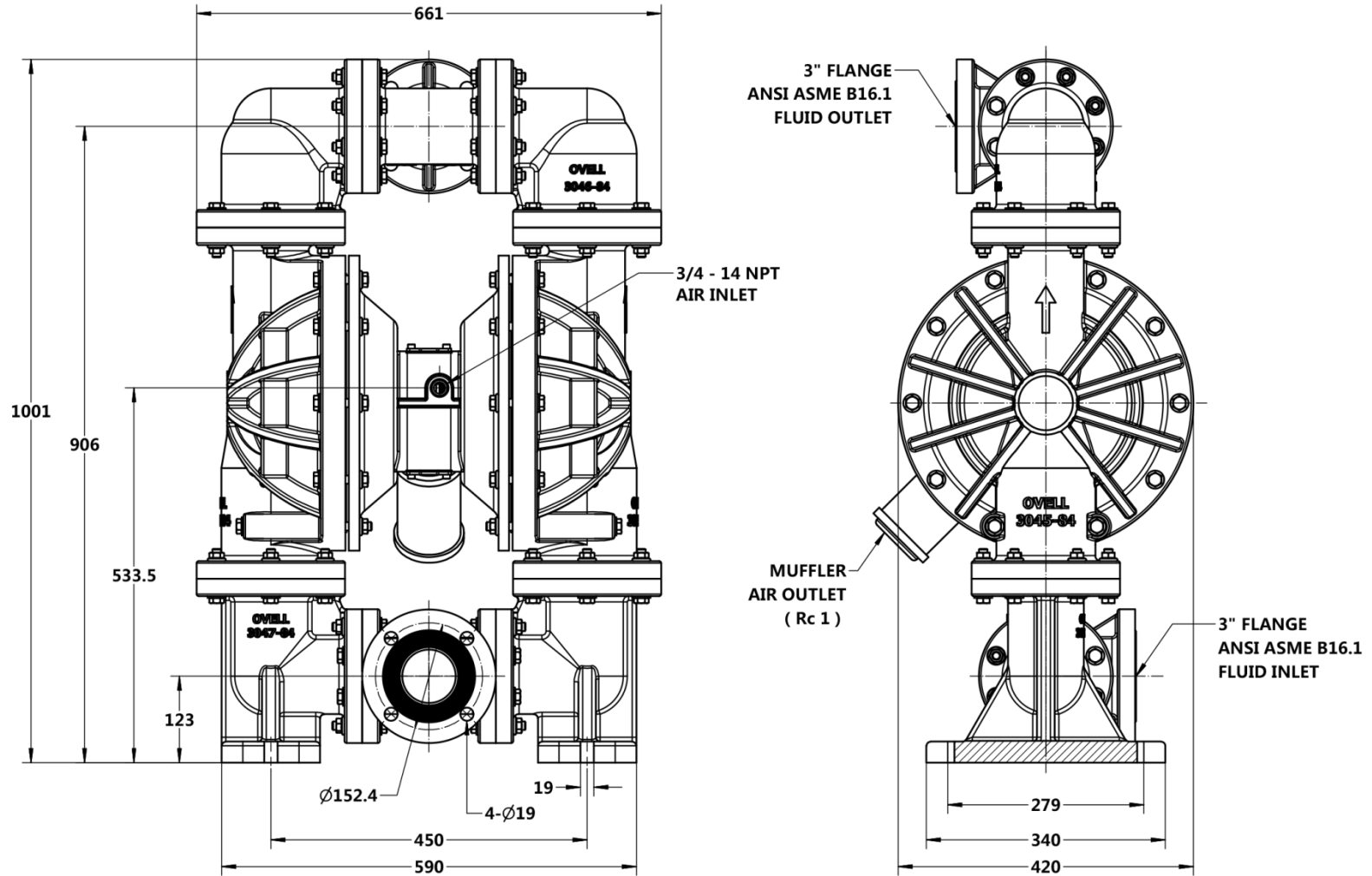

PRINCIPLE OF PUMP OPERATION

This ball type check valve pump is powered by compressed air and is a 1:1 ratio design. The inner side of one diaphragm chamber is alternately pressurized while simultaneously exhausting the other inner chamber. This causes the diaphragms, which are connected by a common rod secured by plates to the centers of the diaphragms, to move in a reciprocating action. (As one diaphragm performs the discharge stroke the other diaphragm is pulled to perform the suction stroke in the opposite chamber.) Air pressure is applied over the entire inner surface of the diaphragm while liquid is discharged from the opposite side of the diaphragm. The diaphragm operates in a balanced condition during the discharge stroke which allows the pump to be operated at discharge heads over 200 feet (61 meters) of water.

For maximum diaphragm life, keep the pump as close to the liquid being pumped as possible. Positive suction head in excess of 10 feet of liquid (3.048 meters) may require a back pressure regulating device to maximize diaphragm life.

Alternate pressurizing and exhausting of the diaphragm chamber is performed by an externally mounted, pilot operated, four way spool type air distribution valve. When the spool shifts to one end of the valve body, inlet pressure is applied to one diaphragm chamber and the other diaphragm chamber exhausts. When the spool

shifts to the opposite end of the valve body, the pressure to the chambers is reversed. The air distribution valve spool is moved by an internal pilot valve which alternately pressurizes one end of the air distribution valve spool while exhausting the other end. The pilot valve is shifted at each end of the diaphragm stroke when an actuator plunger is contacted by the diaphragm plate. This actuator plunger then pushes the end of the pilot valve spool into position to activate the air distribution valve.

The chambers are connected with manifolds with a suction and discharge check valve for each chamber, maintaining flow in one direction through the pump.

INSTALLATION AND START-UP

Locate the pump as close to the product being pumped as possible. Keep the suction line length and number of fittings to a minimum. Do not reduce the suction line diameter.

For installations of rigid piping, short sections of flexible hose should be installed between the pump and the piping. The flexible hose reduces vibration and strain to the pumping system. To reduce the pulsation in flow a suggestion to install a surge suppressor in discharge pipe line.

AIR SUPPLY

Air supply pressure cannot exceed 125 psi (8.6 bar). Connect the pump air inlet to an air supply of sufficient capacity and pressure required for desired performance. When the air

supply line is solid piping, use a short length of flexible hose not less than ½" (13mm) in diameter between the pump and the piping to reduce strain to the piping. The weight of the air supply line, regulators and filters must be supported by some means other than the air inlet cap. Failure to provide support for the piping may result in damage to the pump. A pressure regulating valve should be installed to insure air supply pressure does not exceed recommended limits.

AIR VALVE LUBRICATION

The air distribution system adopts a lubrication-free design, which is the standard operating mode. If the user's actual air source quality is not good or there are special circumstances, consider lubricating the air circuit. But please try to consult the agent or manufacturer in advance.

AIR LINE MOISTURE

Water in the compressed air supply can create problems such as icing or freezing of the exhaust air, causing the pump to cycle erratically or stop operating. Water in the air supply can be reduced by using a point-of-use air dryer

to supplement the user's air drying equipment. This device removes water from the compressed air supply and alleviates the icing or freezing problems.

AIR INLET AND PRIMING

To start the pump, open the air valve approximately ½ to ¾ turn. After the pump primes, the air valve can be opened to increase air flow as desired. If opening the valve increases cycling rate, but does not increase the rate of flow, cavitation has occurred. The valve should be closed slightly to obtain the most efficient air flow to pump flow ratio.

BETWEEN USES

When the pump is used for materials that tend to settle out or solidify when not in motion, the pump should be flushed after each use to prevent damage. (Product remaining in the pump between uses could dry out or settle out. This could cause problems with the diaphragms and check valves at restart.) In freezing temperatures the pump must be completely drained between uses in all cases.

TYPICAL INSTALLATION GUIDE

Available from
Overalllead Inc.



CAUTION
The air exhaust should be piped to an area for safe disposition of the product being pumped, in the event of a diaphragm failure.

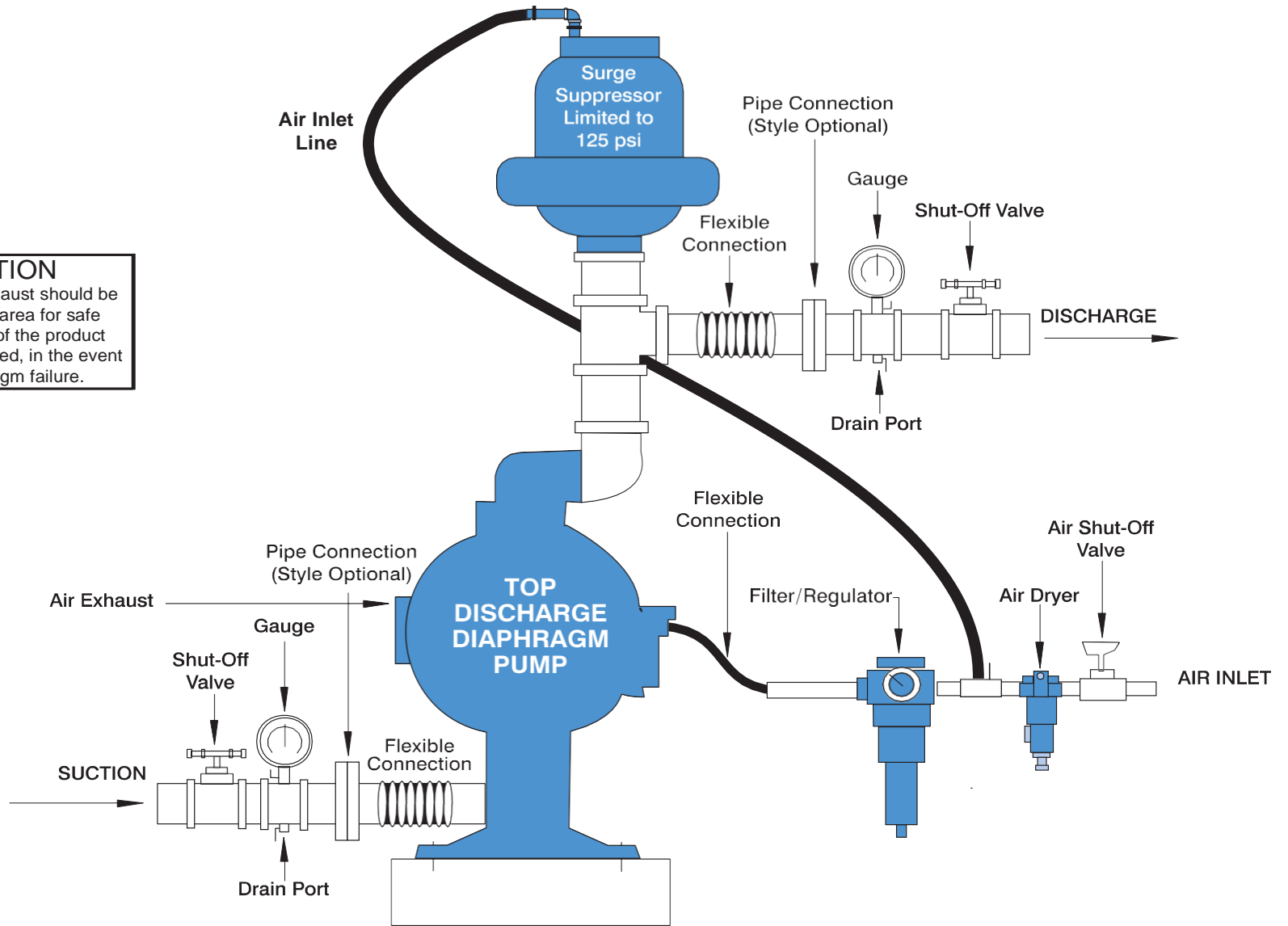

TROUBLESHOOTING

Possible Symptoms:

- Pump will not cycle.
- Pump cycles, but produces no flow.
- Pump cycles, but flow rate is unsatisfactory.
- Pump cycle seems unbalanced.
- Pump cycle seems to produce excessive vibration.

What to Check: Excessive suction lift in system.

Corrective Action: For lifts exceeding 20 feet (6 meters), filling the pumping chambers with liquid will prime the pump in most cases.

What to Check: Excessive flooded suction in system.

Corrective Action: For flooded conditions exceeding 10 feet (3 meters) of liquid, install a back pressure device.

What to Check: System head exceeds air supply pressure.

Corrective Action: Increase the inlet air pressure to the pump. Most diaphragm pumps are designed for 1:1 pressure ratio at zero flow.

What to Check: Air supply pressure or volume exceeds system head.

Corrective Action: Decrease inlet air pressure and volume to the pump as calculated on the published PERFORMANCE CURVE. Pump is cavitating the fluid by fast cycling.

What to Check: Undersized suction line.

Corrective Action: Meet or exceed pump connection recommendations shown on the DIMENSIONAL DRAWING.

What to Check: Restricted or undersized air line.

Corrective Action: Install a larger air line and connection. Refer to air inlet recommendations shown in your pump's SERVICE MANUAL.

What to Check: Check ESADS, the Externally Serviceable Air Distribution System of the pump.

Corrective Action: Disassemble and inspect the main air distribution valve, pilot valve and pilot valve actuators. Refer to the parts drawing and air valve section of the SERVICE MANUAL. Check for clogged discharge or closed valve before reassembly.

What to Check: Rigid pipe connections to pump.

Corrective Action: Install flexible connectors and a surge suppressor.

What to Check: Blocked air exhaust muffler.

Corrective Action: Remove muffler screen, clean or de-ice and reinstall. Refer to the Air Exhaust section of your pump SERVICE MANUAL.

What to Check: Pumped fluid in air exhaust muffler.

Corrective Action: Disassemble pump chambers. Inspect for diaphragm rupture or loose diaphragm plate assembly. Refer to the Diaphragm Replacement section of your pump SERVICE MANUAL.

What to Check: Suction side air leakage or air inproduct.

Corrective Action: Visually inspect all suction side gaskets and pipe connections.

What to Check: Obstructed check valve.

Corrective Action: Disassemble the wet end of the pump and manually dislodge obstruction in the check valve pocket. Refer to the Check Valve section of the pump SERVICE MANUAL for disassembly instructions.

What to Check: Worn or misaligned check valve or check valve seat.

Corrective Action: Inspect check valves and seats for wear and proper seating. Replace if necessary. Refer to Check Valve section of the pump SERVICE MANUAL for disassembly instructions.

What to Check: Blocked suction line.

Corrective Action: Remove or flush obstruction. Check and clear all suction screens and strainers.

What to Check: Blocked discharge line.

Corrective Action: Check for obstruction or closed discharge line valves.

What to Check: Blocked pumping chamber.

Corrective Action: Disassemble and inspect the wetted chambers of the pump. Remove or flush any obstructions. Refer to the pump SERVICE MANUAL for disassembly instructions.

What to Check: Entrained air or vapor lock in one or both pumping chambers.

Corrective Action: Purge chambers through tapped chamber vent plugs. PURGING THE CHAMBERS OF AIR CAN BE DANGEROUS! Contact the Overallled Technical Services Group before performing this procedure. Any model with top-ported discharge will reduce or eliminate problems with entrained air.

If your pump continues to perform below your expectations, contact your local Overallled Distributor or factory Technical Services Group for a service evaluation.

RECYCLING

Many components of OVELL AODD pumps are made of recyclable materials. We encourage pump users to recycle worn out parts and pumps whenever possible, after any hazardous pumped fluids are thoroughly flushed.

IMPORTANT SAFETY INFORMATION



IMPORTANT

Read these safety warnings and instructions in this manual completely, before installation and start-up of the pump. It is the responsibility of the purchaser to retain this manual for reference. Failure to comply with the recommendations stated in this manual will damage the pump, and void factory warranty.



CAUTION

Before pump operation, inspect all gasketed fasteners for looseness caused by gasket creep. Re-torque loose fasteners to prevent leakage. Follow recommended torques stated in this manual.



WARNING

Before maintenance or repair, shut off the compressed air line, bleed the pressure, and disconnect the air line from the pump. The discharge line may be pressurized and must be bled of its pressure.



WARNING

In the event of diaphragm rupture, pumped material may enter the air end of the pump, and be discharged into the atmosphere. If pumping a product which is hazardous or toxic, the air exhaust must be piped to an appropriate area for safe disposition.



WARNING

Take action to prevent static sparking. Fire or explosion can result, especially when handling flammable liquids. The pump, piping, valves, containers or other miscellaneous equipment must be grounded. (See Page 8)



WARNING

This pump is pressurized internally with air pressure during operation. Always make certain that all bolting is in good condition and that all of the correct bolting is reinstalled during assembly.



WARNING

When used for toxic or aggressive fluids, the pump should always be flushed clean prior to disassembly.



WARNING

Before doing any maintenance on the pump, be certain all pressure is completely vented from the pump, suction, discharge, piping, and all other openings and connections. Be certain the air supply is locked out or made non-operational, so that it cannot be started while work is being done on the pump. Be certain that approved eye protection and protective clothing are worn all times in the vicinity of the pump. Failure to follow these recommendations may result in serious injury or death.



WARNING

Airborne particles and loud noise hazards. Wear ear and eye protection.

Exploded View

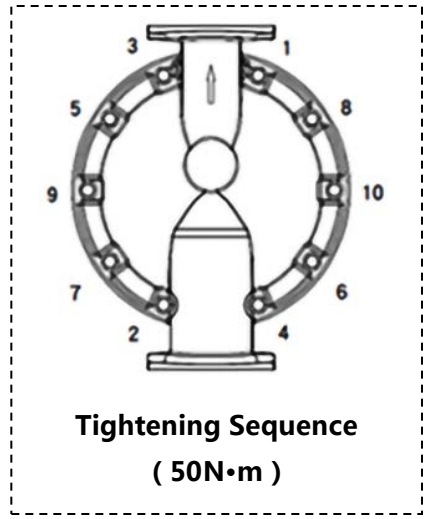
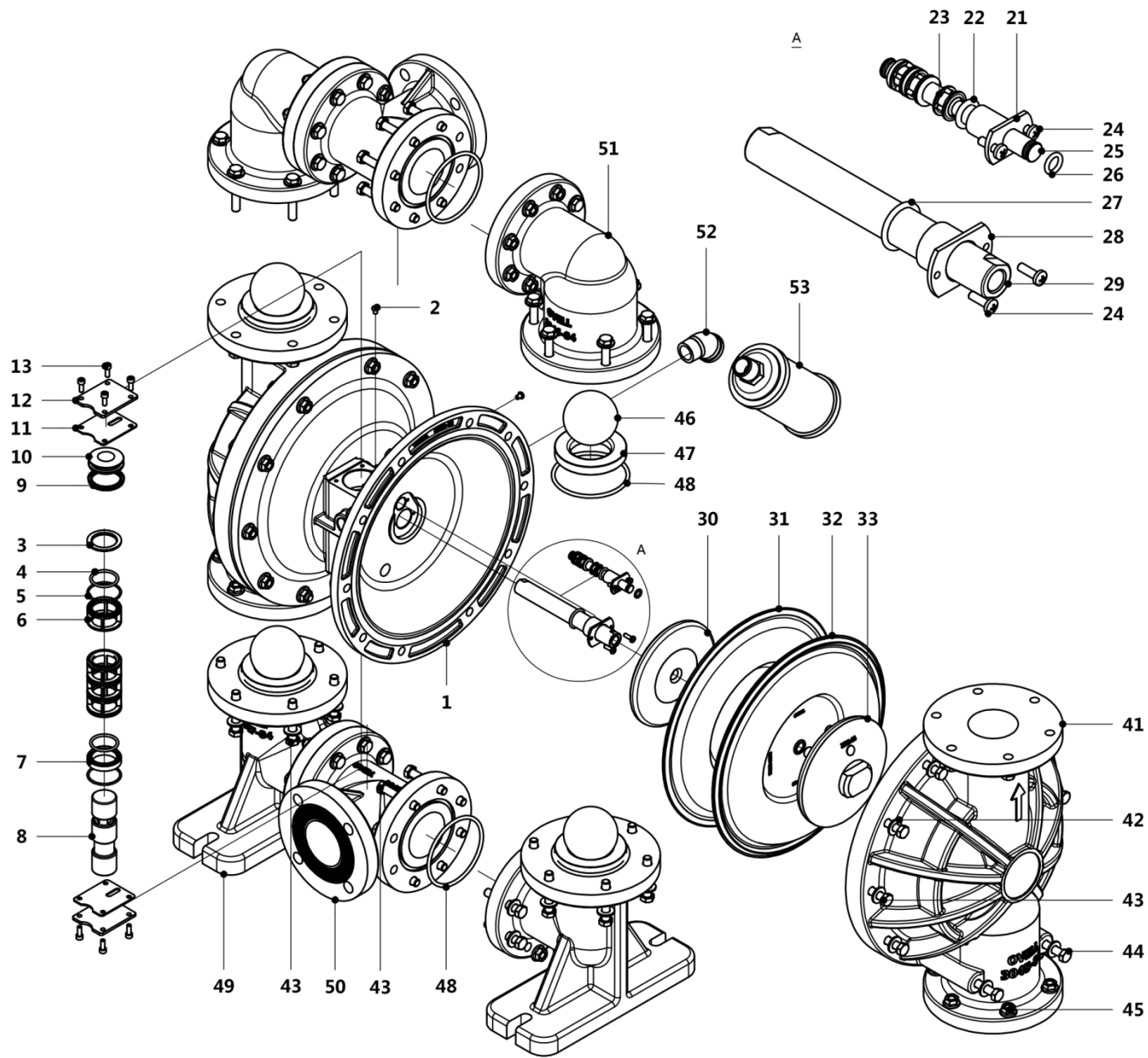

Parts Listing

Item	Description	Part NO.	QTY
1	Motor Body	3001-81	1
2	Bolt	1002-82	2
3	Washer	2041-81	1
		2041-81-L	
Δ4	O Ring	2005-87	5
Δ5	O Ring	2006-87	6
6	Spacer	2042-81	4
		2042-81-L	
7	Washer	2043-81	1
		2043-81-L	
8	Spool	2007-81	1
Δ9	U Cup	2008-87	1
10	Piston	2009-84	1
Δ11	Gasket	2010-87	2
12	Plate	2011-82	2
13	Bolt	2013-82	8
21	Sleeve Bushing	2022-84	2
		2022-81	
Δ22	O Ring	1016-90	4
23	Spacer	1017-81	3
		1017-81-L	
24	Bolt	2039-82	8
25	Pilot Rod	2023-83	1
Δ26	O Ring	1022-90	2
		1022-85-L	
Δ▲27	O Ring	2017-87	2
28	Sleeve Bushing	2018-84	2
		2018-81	
29	Shaft	3049-83	1

Item	Description	Part NO.	QTY
30	Plate	2025-81	2
		2025-82	
▲31	Diaphragm	3066-85	2
▲32	Diaphragm	3067-86	2
		3044-85	
33	Plate	2051-84	2
		2051-99	
41	Fluid Cap	3045-84	2
		3045-99	
42	Plate	3041-82	76
43	Bolt	3043-82	72
44	Bolt	3042-82	4
45	Nut	3031-82	76
▲46	Valve Ball	3032-85	4
		3032-86	
▲47	Valve Seat	3033-84	4
		3033-99	
		3033-82	
		3033-85	
▲48	O Ring	3034-89	8
		3034-96	
49	Supporting Foot	3047-84	2
		3047-99	
50	T-branch Pipe	3048-84	2
		3048-99	
51	Elbow	3046-84	2
		3046-99	
52	Elbow	3089-82	1
53	Muffler	3056-93	1
		3056-93-L	

Material No.	Material
81	Alumimum Alloy
82	Stainless Steel
83	Carbon Steel
84	Plastic
85	Santoprene
86	PTFE, Teflon
87	Buna N, Nitril
88	Fluororubber, Viton
89	EPDM
90	PU(Polyurethane)
91	HytreI
92	Neoprene
93	Assembly, Sub-assembly
94	Paper
95	Cuprum
96	PTFE & Fluororubber
99	PVDF (Kynar)
00	Lubricant

“Δ” : Air Valve Service Kit 7020 (Including Lubricant 1000-00) .

“▲” : Fluid Section Service Kit 8030 (Including Lubricant 1000-00).

Note: Item 31 only used together with 3067-86 for A30XXTXX.

Note: If serial number 47 is selected as 3033-85, the number of serial number 48 parts is 4.

Note: The lithium industry pump type is recommended to be suffixed with "-L" parts.



Declaration of Conformity

Manufacturer:

**Overallead Corporation, Room 902, No.2 Building, No. 3, Chanxing 1st Road,
Xianchong Village, Chencun Town, Shunde District, Foshan City, Guangdong Province,
China**

Certifies that Air-Operated Double Diaphragm Pumps Series:

A Non-Metallic, A Metallic comply with the European Machinery Directive 2006/42/EC. This product has used EN ISO12100:2010, EN809:1998+A1:2009, EN ISO4414:2010 Pumps and Pump Units for Liquids - Common Safety Requirements harmonized standard to verify conformance.

Pump Models:

A05APabc, A10AAabc, A15AAabc, A20AAabc, A30AAabc, A05APabc-L, A10AAabc-L, A15AAabc-L,
A20AAabc-L, A30AAabc-L, A05SPabc, A10SAabc, A15SAabc, A20SAabc, A30SAabc, A02P(K)Pabc,
A05P(K)Pabc, A10P(K)Pabc, A15P(K)Pabc, A20P(K)Pabc, A30P(K)Pabc
(a=T, G, B, H, V, N, E indicate different Diaphragm Material;
b=T, G, B, S, V, N, E indicate different Ball Material;
c=A, S, P, C, G, K, T indicate different Ball Seat Material)



Peter Lee
Quality Representative

August 1, 2022